

Valve Fittings and Wellhead accessories.

Wide range of lubrication accessories such as: grease fitting, vented valve, check valves and packing injector fittings and other oil equipment.

Covers requirements of both maintenance and repair services as OEM's manufacturers.

This valves are made with stainless or carbon steel body. Inner parts, balls and springs are made of stainless steel. For service pressure to 10,000 psi

Some models available in version NACE MR-75-01, for service with Sour Gas. Please, consult.



VDR Double Ball Check Valve

Internal check valve. With double ball and o'ring seal.

Model	Thread	Material		
		Body	Balls	O'ring
VDR 38 C NPS	3/8" NPS	Zinc. carbon steel	SAE 52100	Buna N
VDR 38 C BSP	3/8" BSP	Zinc. carbon steel	SAE 52100	Buna N
VDR 38 I NPS	3/8" NPS	316 SS	316 SS	Fluoroelastomer
VDR 38 I BSP	3/8" BSP	316 SS	316 SS	Fluoroelastomer

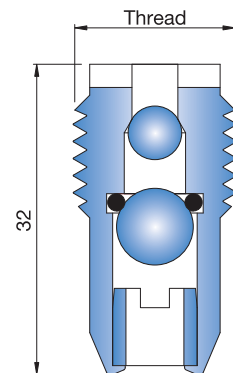

Maximum pressure service @70°F: 6000 psi

VENT Vent fitting

ABAC VENT has a strong back stop stem with hexagonal head. The design prevents impurities from blocking the vent orifice.

Model	Thread	Material		Dimensions [mm]	
		Body	Stem	B	C
VENT 50 C	1/2" NPT	Zinc. carbon steel	420 SS	48	22.2
VENT 60 C	3/4" NPT	Zinc. carbon steel	420 SS	48	28.5
VENT 80 C	1" NPT	Zinc. carbon steel	420 SS	54	35
VENT 50 I	1/2" NPT	316 SS	316 SS	48	22.2
VENT 60 I	3/4" NPT	316 SS	316 SS	48	28.5
VENT 80 I	1" NPT	316 SS	316 SS	54	35

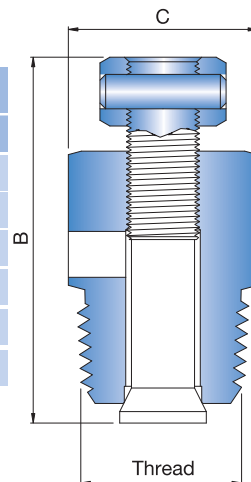

Maximum pressure service @70°F: 10000 psi

ECBT Vented Cap Button head grease fitting

ABAC **ECBT** have vented cap with giant button head. Has UNS 1"x14hpp thread and retention ball with spring return. Ball support allows the passage of grease through the center of the spring, reducing the tendency to "pack-off". Another feature of this standard body grease fitting is the heavy-duty radial rivet crimp that provides the best "blow-out" protection.

Model	Thread	Material		
		Body and cap	Ball	Spring
ECBT50 C	1/2" NPT	Zinc. carbon steel	SAE 52100	302 SS
ECBT50 I	1/2" NPT	316 SS	316 SS	302 SS

Maximum pressure service @70°F: 10000 psi

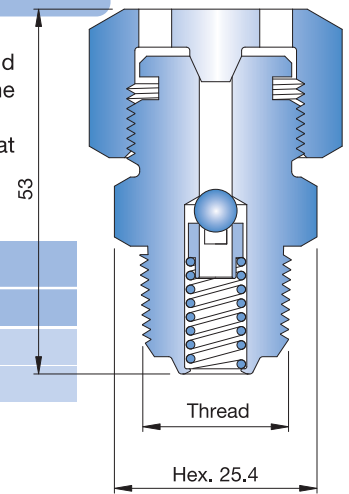

ECB Button head grease fitting

ABAC **ECB** have giant button head and double ball retention, with spring return. Elastomeric main seal to assure zero leak

Model	Thread NPT	Material				(mm) B
		Body	Ball	Seal	Spring	
ECB25-C	1/4"	Zinc carbon steel	SAE 52100	Buna	302 SS	37
ECB50-C	1/2"	Zinc carbon steel	SAE 52100	Buna	302 SS	41
ECB25-I	1/4"	316 SS	316 SS	Fluoro elastomer	302 SS	37
ECB50-I	1/2"	316 SS	316 SS	Fluoro elastomer	302 SS	41

Maximum pressure service @ 70°F: 10000 psi

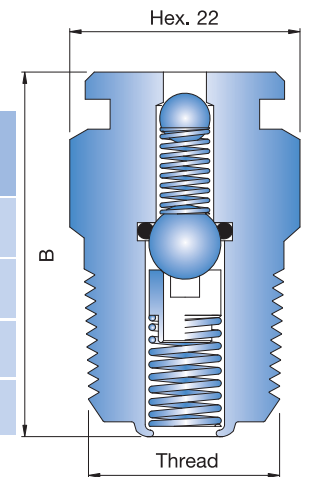

INyec Sealing Injector

Accessory for manual injection of the sealant. Hexagonal wrench operation. Body and injector screw of zincated carbon steel. SAE 52100 ball. 1/2" NPTM connection.

Maximum pressure service @ 70°F: 10000 psi

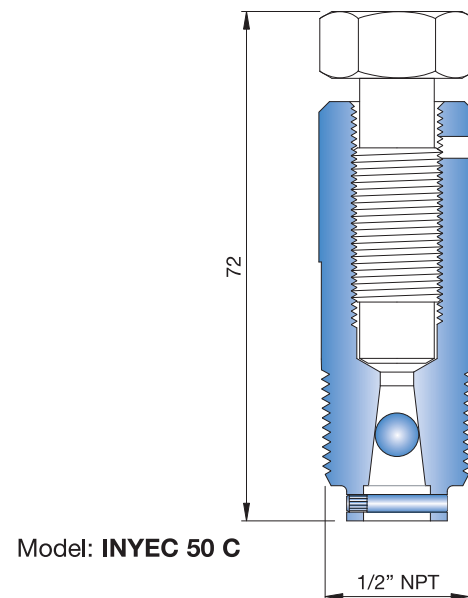

Model: **INyec 50 C**